

TN311 VT-3A130-SYF VHF AM Synthesized Transmitter

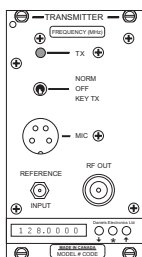

The VT-3A130-S transmitter is a synthesized multichannel AM transmitter capable of operating in 25 / 8.333 KHz channels. The VT-3A130-S transmitter operates in the 118 to 137 MHz aviation band. A modular design allows each of the transmitter's modules, MT-3 Transmitter Mainboard, MT-3 Audio Processor, VT-3A130 Amplifier, and OST-3A130 Synthesizer, to be individually assembled and tested. This facilitates construction, tuning and maintenance as well as troubleshooting procedures. The synthesizer module can be programmed to have up to 16 channels in the 118 to 137 MHz frequency band. Channel 16 can be programmed from the front panel frequency select handle.

Specifications

Frequency Band	118 - 137 MHz
Channel Spacing	8.333 & 25 KHz
Frequency Switching Range	Full Band
RF Output Power	1.0 to 3.0 Watts adjustable (carrier only)
Duty Cycle	100% (-40°C to +60°C)
Emission of Radio Frequency Energy	≤ -60 dBc
Carrier Noise Level	≥ 45 dB
Frequency Stability	± 5.0 ppm (-30°C to +60°C) (-40°C to +60°C optional)
Emission Designator	6K00A3E (AM)
Audio Frequency Distortion (-40°C to +60°C)	≤ 15% THD @ 85% modulation (1 KHz Tone, 50 KHz LPF)
Audio Frequency Response	+1, -5 dB (350 to 2500 Hz)
Operating Temperature	-30°C to +60°C (-40°C to +60°C optional)
Standby Current	≤ 15 mA
Transmit Current (3.0 W)	≤ 2.50 A

Specifications tested using RTCA DO-186B and TIA-603-C

Models Available

VT-3A130-SYF410 Enhanced Synthesized, AM, 3.0 W, 118 - 137 MHz, with FP frequency select handle

Transmitter Operating Frequency

The transmitter is initially aligned at the factory for the center of the 118 to 137 MHz frequency range. No re-alignment of the transmitter is required to change frequencies. The transmitter operating frequency can be set as follows:

- Channel 1 is programmed by the four BCD switches located on the Transmitter Mainboard.
- Channels 2 through 15 are programmed in the synthesizers' internal memory (done at the factory, or by a synthesizer channel programmer).
- Channel 16 is programmed by the front panel frequency select handle (exclusive to the AM product).

43 Erie Street
Victoria, B.C.
Canada V8V 1P8

Toll Free Canada & U.S.A.
Phone: 1-800-664-4066
Fax: 1-877-750-0004

International
Phone: 250-382-8268
Fax: 250-382-6139

Internet
Email: sales@danelec.com
Web: www.danelec.com

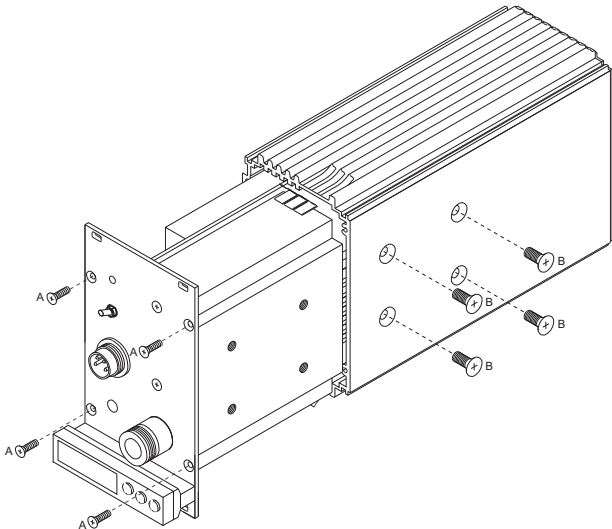
TN311 VT-3A130-SYF VHF AM Synthesized Transmitter

Remove the four front panel screws (A) and four side panel screws (B) to slide the transmitter outer cover off and expose the Main Board, Local Oscillator, Audio Processor Board and Amplifier.

Synthesizer Alignment:

No synthesizer alignment is required. The synthesizer is aligned at the factory for use over the entire frequency range.

Audio Processor Alignment:

No audio processor alignment is required. The audio processor is aligned at the factory for use over the entire frequency range.

Amplifier Output Power Adjustment:

The power amplifier carrier output level can be adjusted from 1.0 to 3.0 Watts. Key the transmitter with no modulation and adjust R19 (RF Level) to achieve the desired RF output power between 1.0 and 3.0 Watts. Apply a 1.0 KHz tone at -8 dBm to the transmitter balanced input and adjust R35 (Balanced AGC Control; on the Audio Processor) to obtain 85% modulation.

Frequency Select Handle Operation:

The frequency select handle is used to designate the operating frequency for channel 16 of the AM RF module. To operate the frequency select handle, set the AM module on channel 16 (using the motherboard jumpers, external control or rotary switch option) and ensure jumper JU73 on older motherboards (pre-2009) is installed.

- 1) The display is normally in a low power sleep mode. To display the current frequency, press either the ↓ (decrease frequency) or the ↑ (increase frequency) buttons. This will display the current channel number (for 2 seconds), then the current frequency (for 3 seconds). The display will then go back to sleep.
- 2) Press the * (center) button to display the current lock status ("Locked" or "Unlocked"). To lock the buttons, press the ↑ button, and to unlock the buttons, press the ↓ button.
- 3) To change the current operating frequency, ensure the lock status is "unlocked", press either ↓ or ↑ to wake up the display, then use the ↓ or ↑ buttons to change the frequency. The ↓ or ↑ buttons have two modes of operation. Single press the buttons for single channel steps (8.333 KHz). Hold the button in for 6 seconds and the frequency will change by 66.66 KHz per step, and after 9 seconds of the button being pressed the frequency will change by 166.66 KHz per step. The operating frequency is set to the displayed value once the ↓ or ↑ buttons are released.

Note: For complete alignment procedures, refer to the instruction manual. These notes are for reference only.

43 Erie Street
Victoria, B.C.
Canada V8V 1P8

Toll Free Canada & U.S.A.
Phone: 1-800-664-4066
Fax: 1-877-750-0004

International
Phone: 250-382-8268
Fax: 250-382-6139

Internet
Email: sales@danelec.com
Web: www.danelec.com