

TN213 VR-3A130-SYF VHF AM Enhanced Receiver

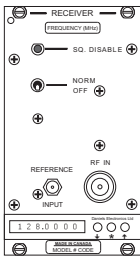

The VR-3A130 Receiver is a multichannel synthesized low power AM receiver capable of operating for regular AM voice radios in 8.333 and 25 KHz channel spacings. The VR-3A130-S receiver operates in the 118 to 137 MHz aviation band. A modular design allows each of the receiver's two internal modules, the Main Receiver Board, and OSR-3A130 Synthesizer, to be individually assembled and tested. This facilitates construction, tuning and maintenance as well as troubleshooting procedures. The synthesizer module can be programmed to have up to 16 channels in the 118 to 137 MHz frequency band. Channel 16 can be programmed from the front panel frequency select handle.

Specifications

Frequency Band	118 - 137 MHz
Channel Spacing	8.333 & 25 KHz
Frequency Switching Range	Full Band
Sensitivity (for 6 dB S/N)	≤ -110 dBm
Sensitivity (for 10 dB SINAD)	≤ -107 dBm @ 128 MHz, +25°C
Selectivity (6 dB Nose Bandwidth)	≥ 2.77 KHz (±)
Selectivity (60 dB Skirt Bandwidth)	≤ 7.37 KHz (±)
Spurious Responses	≥ 100 dB
Intermodulation Response Rejection	≥ 110 dB
Noise Level	≤ -40 dB
L.O. Frequency Stability	± 5.0 ppm (-30°C to +60°C) (-40°C to +60°C optional)
Distortion (THD) (-40°C to +60°C)	≤ 10% @ 85% modulation
AGC Attack Time / AGC Decay Time	≤ 40 ms / ≤ 140 ms
Audio Squelch Sensitivity	≥ 8 dB SINAD close point / ≤ 20 dB SINAD open point
Squelch Hysteresis	0 to 8 dB
Operating Temperature	-30°C to +60°C (-40°C to +60°C optional)
Operating Current (Squelched)	≤ 117 mA

Specifications tested using RTCA DO-186B and ETSI EN300 676 Section 8.8

Models Available

VR-3A130-SYF210 Enhanced Synthesized, AM, 118 - 137 MHz, with FP frequency select handle

Receiver Operating Frequency

The receiver is initially aligned at the factory for the center of the 118 to 137 MHz frequency range. No re-alignment of the receiver is required to change frequencies. The receiver operating frequency can be set as follows:

- Channel 1 is programmed by the four BCD switches located on the Receiver Mainboard.
- Channels 2 through 15 are programmed in the synthesizers' internal memory (done at the factory, or by a synthesizer channel programmer).
- Channel 16 is programmed by the front panel frequency select handle (exclusive to the AM product).

43 Erie Street
Victoria, B.C.
Canada V8V 1P8

Toll Free Canada & U.S.A.
Phone: 1-800-664-4066
Fax: 1-877-750-0004

International
Phone: 250-382-8268
Fax: 250-382-6139

Internet
Email: sales@danelec.com
Web: www.danelec.com

TN213 VR-3A130-SYF VHF AM Enhanced Receiver

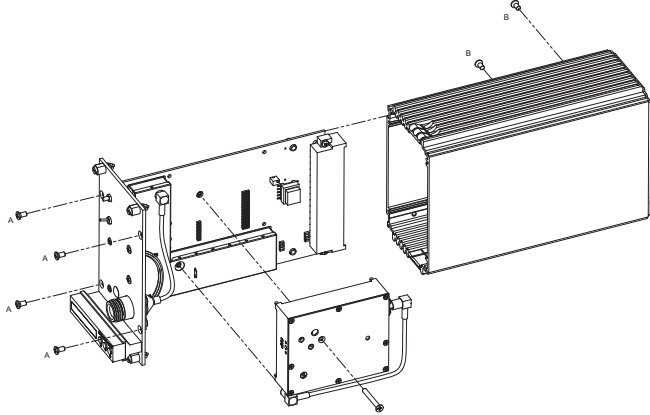

Remove the four front panel screws (A) and two side panel screws (B) to slide the receiver outer cover off and expose the Receiver Main Board and Synthesizer. Two holes on the side of the case have no screws.

Squelch Adjustments:

Receiver squelch action is factory set to establish a squelch hysteresis window of 4 dB, such that the squelch closes at the 8 dB SINAD point and opens 4 dB above. Eg. if the receiver 8 dB SINAD point is -108 dBm the receiver should be set to unsquelch at -104 dBm and squelch at -108 dBm. Rotate the squelch hysteresis adjust potentiometer (RV8) and the squelch threshold potentiometer (RV7) fully counter clockwise. Inject a 1 KHz tone at 30% modulation at the 8 dB SINAD level. Note the RF level and then increase it by 4 dB. Slowly adjust the squelch threshold potentiometer (RV7) clockwise until the receiver squelches. Change the RF level back to the 8 dB SINAD level noted earlier. Advance the squelch hysteresis adjust potentiometer (RV8) clockwise while momentarily pressing the squelch disable switch repeatedly, until the squelch gate just stays open. Then adjust the squelch hysteresis adjust potentiometer (RV8) counter clockwise without pressing the squelch disable button until the squelch gate just closes.

Front End Alignment:

No front end alignment is required. The enhanced synthesized receiver uses an elliptical band pass filter that is tuned at the factory for the entire frequency band of 118 - 137 MHz.

Synthesizer Alignment:

No synthesizer alignment is required. The synthesizer is factory aligned for use over the entire frequency range.

Frequency Select Handle Operation:

The frequency select handle is used to designate the operating frequency for channel 16 of the AM RF module. To operate the frequency select handle, set the AM module on channel 16 (using the motherboard jumpers, external control or rotary switch option) and ensure jumper JU73 on older motherboards (pre-2009) is installed.

- 1) The display is normally in a low power sleep mode. To display the current frequency, press either the ↓ (decrease frequency) or the ↑ (increase frequency) buttons. This will display the current channel number (for 2 seconds), then the current frequency (for 3 seconds). The display will then go back to sleep.
- 2) Press the * (center) button to display the current lock status ("Locked" or "Unlocked"). To lock the buttons, press the ↑ button, and to unlock the buttons, press the ↓ button.
- 3) To change the current operating frequency, ensure the lock status is "unlocked", press either ↓ or ↑ to wake up the display, then use the ↓ or ↑ buttons to change the frequency. The ↓ or ↑ buttons have two modes of operation. Single press the buttons for single channel steps (8.333 KHz). Hold the button in for 6 seconds and the frequency will change by 66.66 KHz per step, and after 9 seconds of the button being pressed the frequency will change by 166.66 KHz per step. The operating frequency is set to the displayed value once the ↓ or ↑ buttons are released.

Note: For complete alignment procedures, refer to the instruction manual. These notes are for reference only.

43 Erie Street
Victoria, B.C.
Canada V8V 1P8

Toll Free Canada & U.S.A.
Phone: 1-800-664-4066
Fax: 1-877-750-0004

International
Phone: 250-382-8268
Fax: 250-382-6139

Internet
Email: sales@danelec.com
Web: www.danelec.com